



# JCB LOADALL | 526S



MAX. PAYLOAD:

2.6 tonnes (5730lb)

MAX. LIFT HEIGHT:

5.61 metres (18ft 5in)

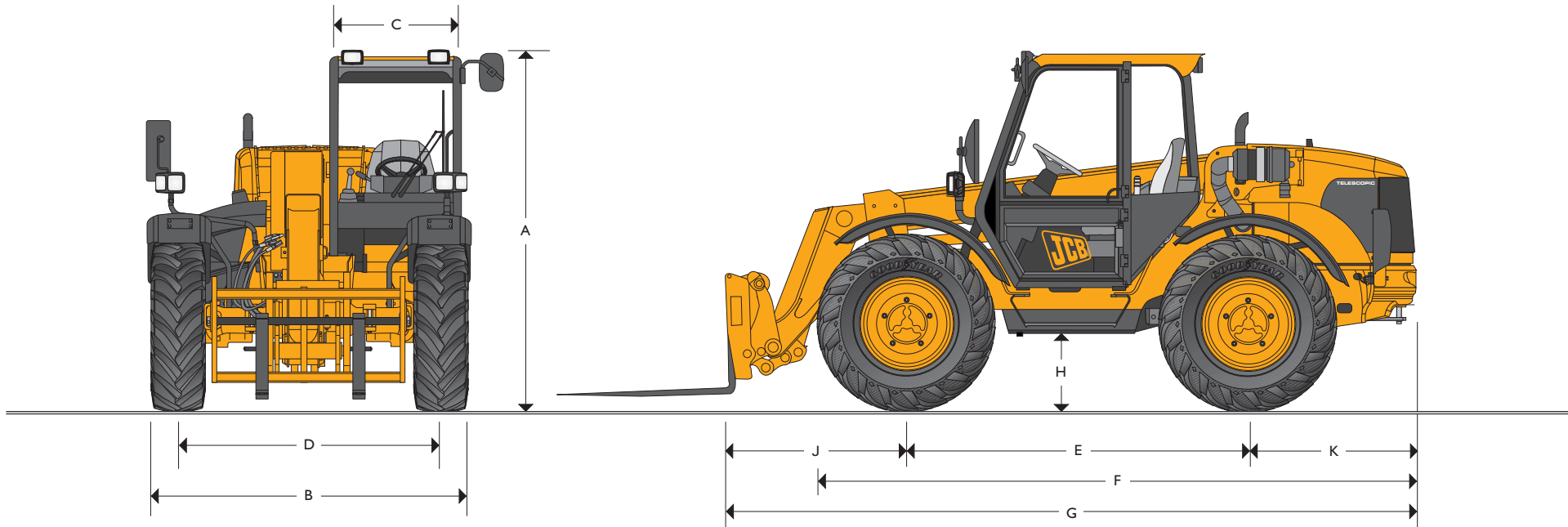

## STATIC DIMENSIONS

Machine model	526S
	m (ft-in)
A Overall height	2.41 (7-11)
B Overall width (over tyres)*	2.22 (7-3)
C Inside width of cab	0.88 (2-11)
D Front track	1.83 (6-0)
E Wheelbase	2.34 (7-8)
F Overall length to front tyres	4.09 (13-5)
G Overall length to front carriage	4.62 (15-1)
H Ground clearance	0.45 (1-6)

Machine model	526S
	m (ft-in)
J Front wheel centre to carriage	1.16 (3-8)
K Rear wheel centre to rear face	1.12 (3-6)
Carriage roll back angle	degrees 42
Carriage dump angle	degrees 33
Outside turn radius (over tyres) 4WS	3.38 (11-1)
Outside turn radius (over forks) 4WS	4.25 (13-11)
Weight	kg (lb) 6280 (13845)
Tyres	15.5x80x24 10PR

\*Dependant upon tyre specified



# JCB LOADALL | 526S



## LIFT PERFORMANCE

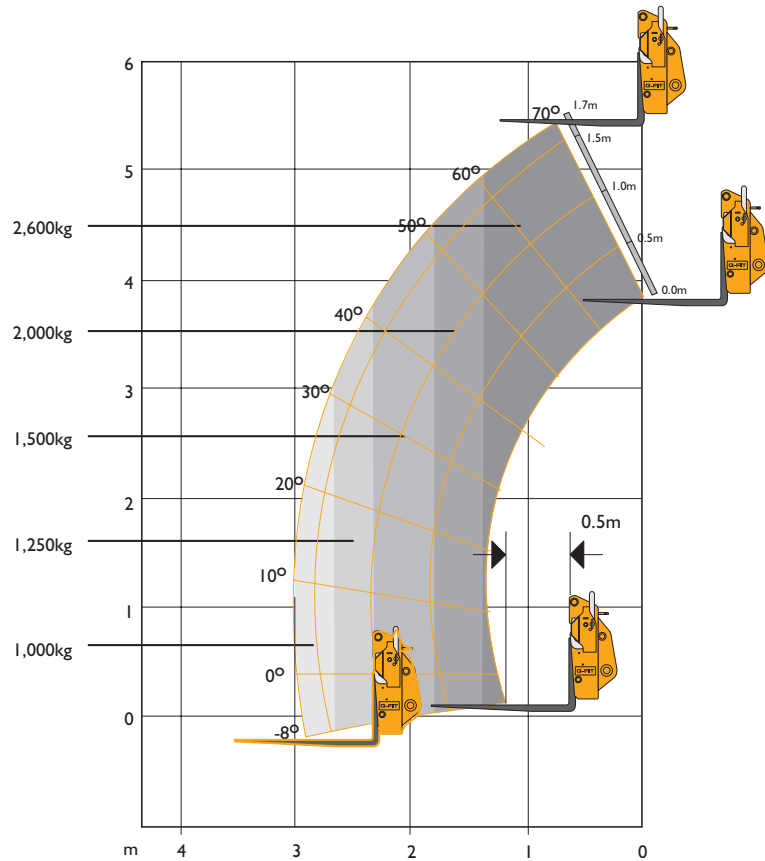

## LIFT PERFORMANCE

Machine Model	526S	
Maximum lift capacity	kg (lb)	2600 (5730)
Lift capacity to full height	kg (lb)	2600 (5730)
Lift capacity at full reach	kg (lb)	1000 (2204)
Lift height	m (ft-in)	5.61 (18-5)
Reach at maximum lift height	m (ft-in)	0.49 (1-7)
Maximum forward reach	m (ft-in)	2.96 (9-8½)
Reach with 1 tonne load	m (ft-in)	2.96 (9-8½)
Placing height	m (ft-in)	4.87 (15-11¾)

Complies with stability test EN 1459 Annex B.



# JCB LOADALL | 526S



## ENGINE

Latest technology and advanced design provides low fuel consumption, reduced noise, high torque and power output, total reliability and minimal maintenance.

Two-stage, dry type air filter with primary and safety elements.

Machine Model – 526-55		Standard	Option
Manufacturer		JCB	JCB
Model		JCB444	JCB444
Displacement	ltr (in <sup>3</sup> )	4.4 (269)	4.4 (269)
No. of cylinders		4	4
Bore size	mm (in)	103 (4.05)	103 (4.05)
Stroke	mm (in)	132 (5)	132 (5)
Aspiration		Naturally aspirated	Turbo
<b>Power rating</b>			
Power @ 2200rpm	kW (HP)	63.0 (84.5)	74.2 (100)
<b>Torque rating</b>			
Torque @ 1200rpm	Nm (lbf ft)	320 (236)	–
Torque @ 1300rpm	Nm (lbf ft)	–	425 (313.5)

## TRANSMISSION

JCB Syncro Shuttle transmission incorporating torque converter, reversing shuttle and all synchromesh 4-speed gearbox in one resiliently mounted unit. Steering column mounted switch incorporating directional control.

Gear lever and loader control transmission disconnect switches for fast gearchanging.

Travel speed 30kph (18.6 mph)

**Front and rear drive axles:** Epicyclic hub reduction type with drop box on front axle. Permanent 4-wheel drive.

## BRAKES

**Service brakes** - Hydraulically operated self-adjusting, oil-immersed multi-disc type.

**Parking brake** - Hand operated disc brake on output of gearbox.

## BOOM AND CARRIAGE

Boom is manufactured from high tensile steel.

Low maintenance, hard wearing pads.

JCB tool carrier parallel lift carriage with pin locking accepts fork frame with integral pallet forks and a wide range of attachments.

## SAFETY CHECK VALVES

Fitted to carriage tilt, telescopic and boom lift rams.

## SERVICE CAPACITIES

Fuel tank	litres (UK gal)	160 (34.6)
Hydraulic tank	litres (UK gal)	100 (22)
Coolant	litres (UK gal)	23 (5.0)

## HYDRAULICS

Single gear pump, fitted with suction strainer and filter. One boom end auxiliary hydraulic service fitted as standard.

Operating system pressure	bar (psi)	241 (3500)
Flow at system pressure @ 2200rpm	ltr/min (gal/min)	80 (17.6)
<b>Hydraulic Cycle Times</b>		<b>Seconds</b>
Boom raise		6.1
Boom lower		4.0
Extend		4.6
Retract		2.5
Bucket dump		2.1
Bucket crowd		3.3

## ELECTRICS

12v negative earth. 145 AH heavy duty battery with isolator. 95 amp alternator. Full road lighting. Reversing light. Direction indicators. Hazard warning. Reverse alarm.

## CAB

Quiet, safe and comfortable cab conforms to ROPS ISO 3471/SAE J1040 and FOPS ISO 3449/SAE J231 Directives. Tinted glass all round, with laminated roof screen. Roof bars, front screen and roof screen wipers and heater/screen demister. Rear opening window with wash/wipe. Audio-visual warning system for coolant temperature, engine oil pressure, air-cleaner, battery charge, transmission oil temperature and pressure, water in fuel, low water level. Hourmeter, road speed indicator and inclinometer. Adjustable suspension seat. Tilt steer column.

### Controls:

Multi lever direct acting hydraulic control levers with joystick control of lift and crowd, gear lever, parkbrake, power shuttle lever. Throttle and brake pedals.

### Load Moment Indicator:

Automatic eye level audio-visual load moment indicator warning system receiving a signal from a load sensor on the rear axle. This system continuously monitors the machine's forward stability and leaves the operator in control at all times.

## STEERING

Hydrostatic power steering with power track rods on both axles.

**Three steer mode options:** front wheel steer; all wheel steer; crab steer; operated from in the cab by a selection lever.

## OPTIONS AND ACCESSORIES

**Options:** Air suspension seat, working lights, rotating flashing beacon, fire extinguisher, front screen guard, air conditioning, radial tyres, mechanical or hydraulic tow hitch for maximum gross weight of 8 tonnes (2 tonnes download on hitch) complete with trailer light socket and trailer tip hydraulics, hydraulic pin locking for attachments, 2 boom end auxiliary services. Powershift transmission, single lever joystick control, proportional trailer brakes. Sunblind, arm rest.

**Attachments:** available with tool carrier or Q-fit style carriage. Contact your local dealer for details of the comprehensive range.



## A GLOBAL COMMITMENT TO QUALITY

JCB's total commitment to its products and customers has helped it grow from a one-man business into Britain's largest privately owned manufacturer of backhoe loaders, crawler excavators, wheeled excavators, telescopic handlers, wheeled loaders, dump trucks, rough terrain fork lifts, industrial fork lifts, mini/midi excavators, skid steer loaders and tractors.

By making constant and massive investments in the latest production technology, the JCB factories have become some of the most advanced in Europe.

By leading the field in innovative research and design, extensive testing and stringent quality control, JCB machines have become renowned all over the world for performance, value and reliability.

And with a global sales and service network of over 400 distributors and agents, the company exports over 70% of its production to all five continents.

Through setting the standards by which others are judged, JCB has become one of Britain's most impressive success stories.

